

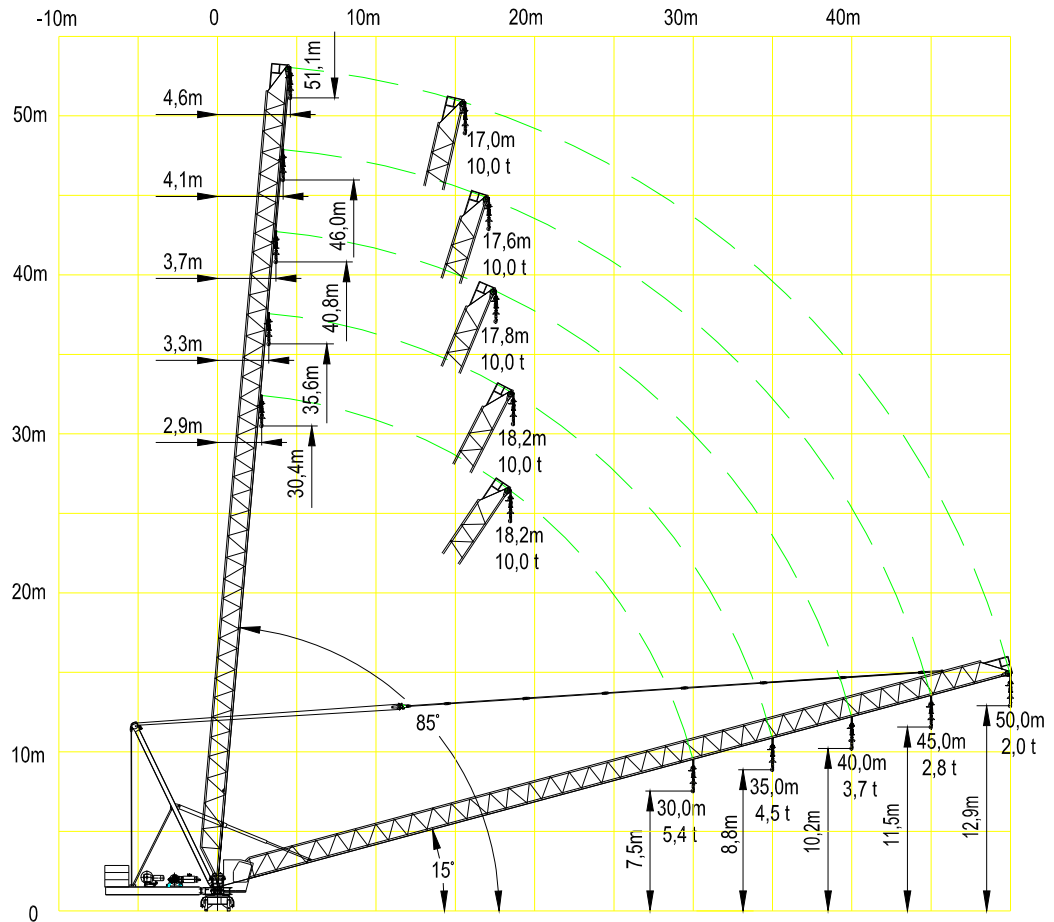









2.1.2 Jib lengths, Load diagrams, Speeds

Luffing jib



Load diagram

JIB 起重臂	Max.load 最大起重量	Jib Reach 臂长											
		t	m	18	20	23	25	28	30	35	40	45	50
50m		5.00	30.0	5.00	5.00	5.00	5.00	5.00	5.00	3.90	3.20	2.50	2.00
		10.00	17.0	10.00	8.32	7.30	6.19	5.30	4.64	3.70	3.00	2.30	1.80
45m		5.00	30.1	5.00	5.00	5.00	5.00	5.00	5.00	4.13	3.28	2.60	
		10.00	17.6	10.00	8.40	7.30	6.30	5.40	4.70	3.93	3.08	2.41	
40m		5.00	30.3	5.00	5.00	5.00	5.00	5.00	5.00	4.18	3.30		
		10.00	17.8	10.00	8.60	7.40	6.55	5.43	4.80	3.98	3.10		
35m		5.00	30.5	5.00	5.00	5.00	5.00	5.00	5.00	4.40			
		10.00	18.2	10.00	9.01	7.50	6.88	5.80	4.84	4.20			
30m		5.00	30.0	5.00	5.00	5.00	5.00	5.00	5.00				
		10.00	18.2	10.00	8.87	7.40	6.60	5.70	5.00				